



GARAGE EQUIPMENT



YONGKANG-CHINA

About us



Yongkang Xieheng Industry & Commerce Co., Ltd is a company specializing in manufacturing automotive service equipments and small construction machines.

We provide a range of high quality products for professional, rental and DIY users, Includes: parts washer, sandblaster, oil drainer, concrete mixer etc.

We hold a strong position for growth and operate with a focused new product development program. Designing right products for right market, we have a dedicated export team focusing their efforts on the international market, listening to our customer's voice and meeting their demand. We keep enhancing good reputation for honest and reliable business conduct among our worldwide customers.

We have established strict quality control system and our tenacious efforts can assure high quality and first-class products. We are looking forward to greater cooperation with overseas customers on the principle of mutual benefits. We warmly welcome you to visit our factory for business.



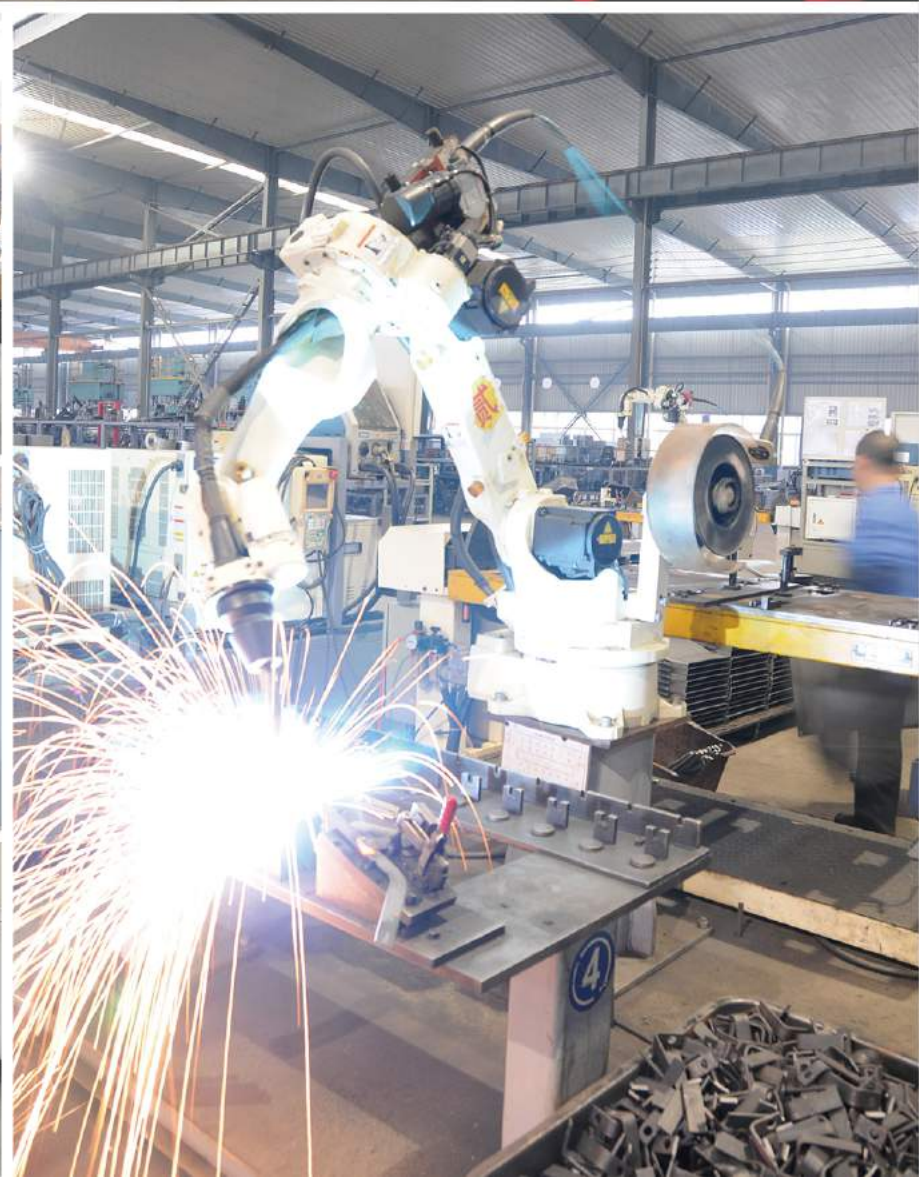

PARTS WASHER



Pneumatic Degreaser-cleaning Tank

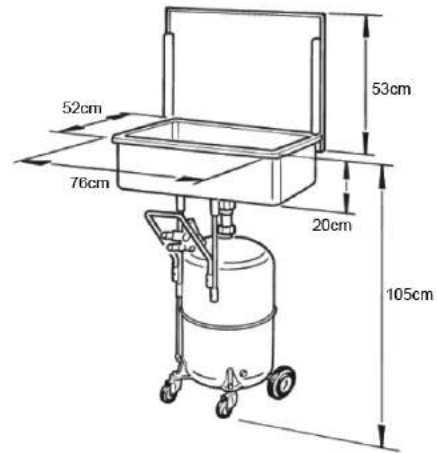

XH-PDCT

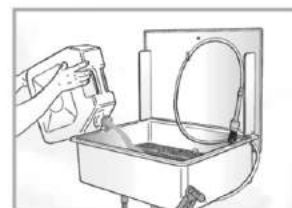
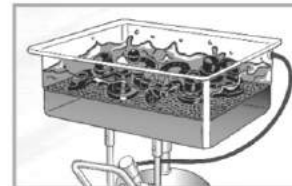
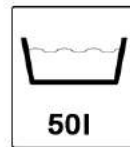

Function:

- ◆ Suitable for rapid cleaning of small mechanical parts, motor parts, etc

Specification:

- ◆ Cleaning tank capacity: 50 Litre
- ◆ Trolley tank capacity: 65 litre with level indicator
- ◆ Compressor supply: 6-8kgs pressure
- ◆ Pressure for output solvent: 0.4-0.5kgs
- ◆ Flowing rate: 130kgs/hour
- ◆ Max working pressure: 125PSI

Item Number	Pcs/ctn	G.W./N.W.	Dimension	Q'ty/40'	Remarks
XH-PDCT	1/2	25/23kgs	78x55x28cm	200set	
	1/2	25/21kgs	78x46x44cm		

40 Gallon Parts Washer

CE

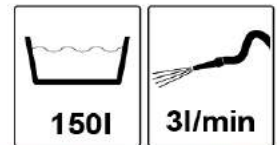

XH-PW40G

**Function:**

- ◆ 40gallon capacity tank is suitable for cleaning larger engine components.
- ◆ Lid of tank tilted with fusible link hinge which automatically snap slide shut in the event of a fire.
- ◆ Parts basket for snaking small parts in solvent.

Specification:

- ◆ Suitable for different kind of solvent at same time.
- ◆ Double driving pump for higher cleaning efficiency.
- ◆ Two Separated tank with perfect weiding seal.
- ◆ Solvent capacity:24Gallons
- ◆ Electrical requirement:110V,60Hz(240V/50Hz)

Item Number	Pcs/ctn	G.W./N.W.	Dimension	Q'ty/20'	Q'ty/40'	Remarks
XH-PW40G	1	45/42kgs	114x55x33cm	145pcs	290pcs	

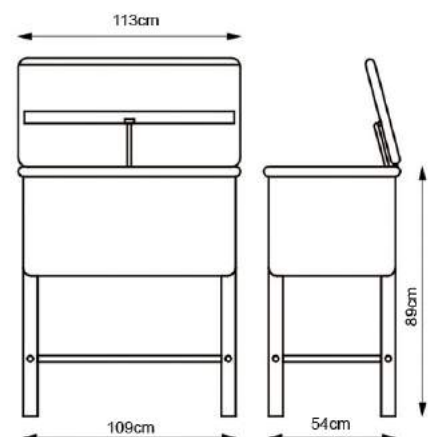



XH-PW40G-II

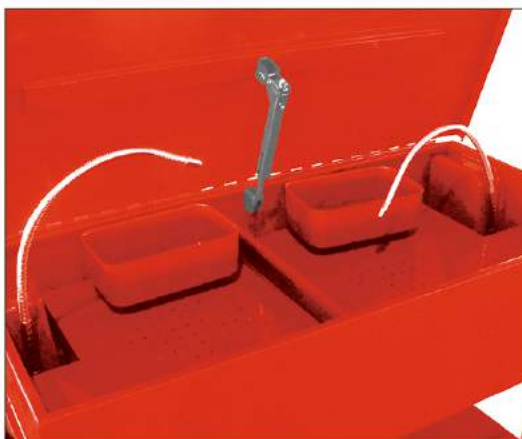
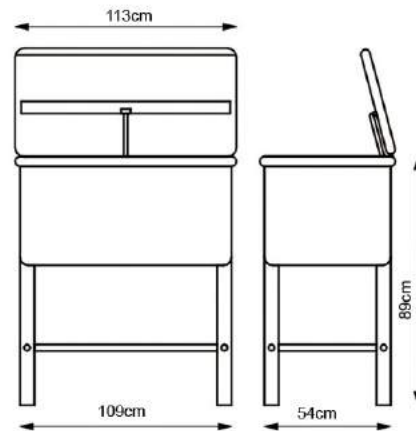
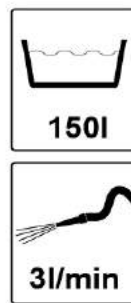

Function:

- ◆ 40gallon capacity tank is suitable for cleaning larger engine components.
- ◆ Lid of tank tilted with fusible link hinge which automatically snap slide shut in the event of a fire.
- ◆ Parts basket for snaking small parts in solvent.

Specification:

- ◆ Suitable for different kind of solvent at same time.
- ◆ Double driving pump for higher cleaning efficiency.
- ◆ Two Separated tank with perfect weiding seal.
- ◆ Solvent capacity:24Gallons
- ◆ Electrical requirement:110V,60Hz(240V/50Hz)

Item Number	Pcs/ctn	G.W./N.W.	Dimension	Q'ty/20'	Q'ty/40'	Remarks
XH-PW40G-II	1	48/45kgs	114x55x36cm	120pcs	250pcs	

20 Gallon Parts Washer

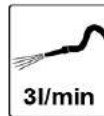
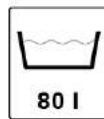
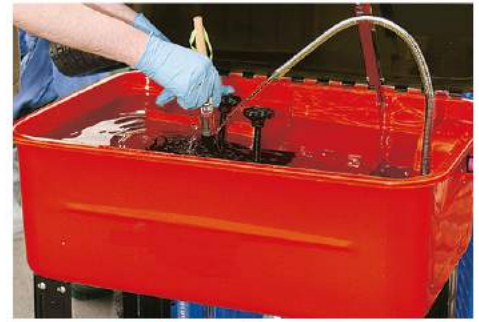
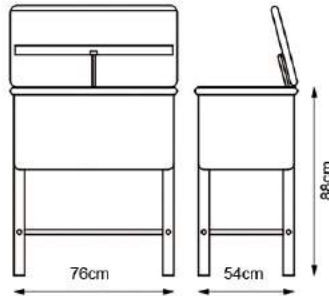

Specification:

- ◆ Rugged welded steel
- ◆ Convenient removable work shelf
- ◆ Parts basket for soaking small parts in solvent
- ◆ Self-latching fused linked fine cover
- ◆ Electric requirement: 110V/60Hz(240V/50Hz)solvent pump
- ◆ Max pump output through spigot:Recirculates2.7-3.3litre/min of solvent
- ◆ Tank capacity:20Gallon
- ◆ Solvent capacity:12Gallon

XH-PW20G

Item Number	Pcs/ctn	G.W./N.W.	Dimension	Q'ty/20'	Q'ty/40'	Remarks
XH-PW20G	1	26/23kgs	79x55x32cm	210pcs	410pcs	

20 Gallon Parts Washer

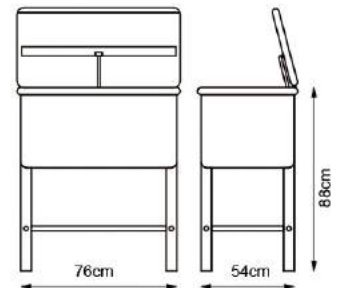
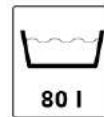

Specification:

- ◆ Rugged welded steel
- ◆ Convenient removable work shelf.
- ◆ Parts basket for soaking small parts in solvent
- ◆ Self-latching fused linked fine cover
- ◆ Electric requirement: 110V/60Hz(240V/50Hz)solvent pump
- ◆ Max pump output through spigot:Recirculates2.7-3.3litre/min of solvent
- ◆ Tank capacity:20Gallon
- ◆ Solvent capacity:12Gallon

XH-PW20G

Item Number	Pcs/ctn	G.W./N.W.	Dimension	Q'ty/20'	Q'ty/40'	Remarks
XH-PW20G	1	26/23kgs	79x55x32cm	210pcs	410pcs	

20 Gallon Parts Washer with Wheels

CE



XH-PW20G/W

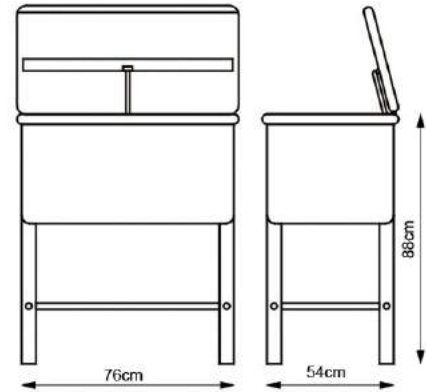
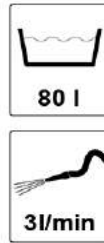

Specification:

- ◆ Rugged welded steel
- ◆ Convenient removable work shelf.(PW20G/W with wheels)
- ◆ Parts basket for snaking small parts in solvent
- ◆ Self-latching fuses linked fine cover
- ◆ Electric requirement: 110V/60Hz(240V/50Hz)solvent pump
- ◆ Max pump output through spigot:Recirculates2.7-3.3litre/min of solvent
- ◆ Tank capacity:20Gallon
- ◆ Solvent capacity:12Gallon

Item Number	Pcs/ctn	G.W./N.W.	Dimension	Q'ty/20'	Q'ty/40'	Remarks
XH-PW20G/W	1	28/25kgs	79x55x32cm	210pcs	410pcs	

20 Gallon Removable Parts Washer with Service Shelf

CE



XH-RPW-20G

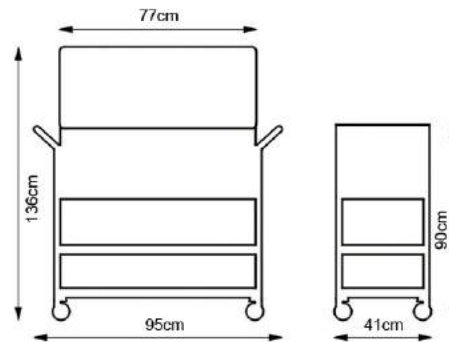

Specification:

- ◆ Electrical requirement:110V/60Hz(240V/50Hz)
- ◆ Pump capacity:317Gallon/hr
- ◆ Includes 4 wheels(2 rigid wheels&2 locking swivel wheels)
- ◆ Tank size:28"x19"x8.2"
- ◆ Assembled dimension:38"x21.5"x37"

Item Number	Pcs/ctn	G.W./N.W.	Dimension	Q'ty/40'	Remarks
XH-RPW-20G	1	37/34kgs	87x57x50cm	224set	

3-1/2 Gallon Parts Washer

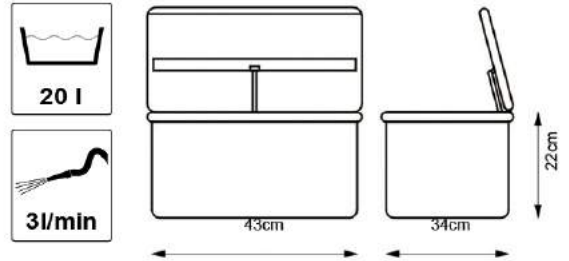

XH-PW3-1/2G

Item Number	Pcs/ctn	G.W./N.W.	Dimension	Q'ty/20'	Q'ty/40'	Remarks
XH-PW3-1/2G	1	7.5/6.5kgs	47x36x25cm	700pcs	1400pcs	

Function:

- ◆ Can be moved easily from one job to another
- ◆ Ideal for small garage, home and business
- ◆ Heavy-duty construction, fusible link, steel lid
- ◆ Removable shelf keeps parts out of solvent during inspection and drying
- ◆ Easy clean up

Specification:

- ◆ Max. Pump output: 2.7~3.3litre/min
- ◆ Tank capacity: 5Gallon
- ◆ Solvent capacity: 3-1/2Gallon
- ◆ Electrical requirement: 110V-120V, 60Hz; 220V-240V, 50Hz

MICRO CLEANER



Foldable



Wall mounting



XH-MC

Item Number	Pcs/ctn	G.W./N.W.	Dimension	Q'ty/20'	Q'ty/40'	Remarks
XH-MC	1	26/24kgs	58x28x66cm	272pcs	548pcs	

Specification:

- ◆ Suitable for rapid cleaning of small mechanical parts, motor parts etc
- ◆ Easy to take, and good for wall mounting, save operating space
- ◆ Overall dimension: 560x545x630mm
- ◆ Max solvent capacity: 14L
- ◆ Flowing rate: 1.9L/min
- ◆ Power: 43W(120V/60Hz); 26W(230V/50Hz)

Multi-circutive pump



XH-MCP

Function:

- ◆ Widely use for the circulation of the detergent.
- ◆ Modeling of home fountain and oxygen circulation for fish raising, while also an ideal implement for small-scale mechanical cooling down circulation, fountain modeling of hotles and restaurants, beaufying the Environment.

Specification:

- ◆ A magnetion sealless pump
- ◆ 110V/60Hz,0.22A(-240/50Hz)
- ◆ Max head:1.8M Max flow Rate:20liter/min

Item Number	Pcs/ctn	G.W./N.W.	Dimension	Q'ty/20'	Q'ty/40'	Remarks
XH-MCP	32	18/16kgs	60x26x19cm	20700pcs	42140pcs	

Parts Washer Brush



XH-BH

Function:

- ◆ It can be used to match with Parts Washer,& is more convenient to wash parts.

Item Number	Pcs/ctn	G.W./N.W.	Dimension	Q'ty/40'	Remarks
XH-BH	36	9/8kgs	52x39x40cm	11880pcs	42140pcs



Mini Parts Washer



XH-MPW



Function:

- ◆ It can be used to wash small parts expediently

Item Number	Pcs/ctn	G.W./N.W.	Dimension	Q'ty/20'	Remarks
XH-MPW	1.2L	12pcs/ctn	10.9/9.9kgs	38x37x35cm	6912pcs
	2L	6pcs/ctn	7.3/6.3kgs	47x25x35cm	3888pcs
	5L	6pcs/ctn	13/12kgs	68.5x35.5x48cm	1152pcs



4



OIL DRAINER

30 Gallon Multi-functional Oil Drainer New Method of Cleaning Up Spills



Function:

- ◆ Creative design for cleaning up spills
- ◆ Also suitable for oil extracting, oil collecting & oil filling
- ◆ Additional large oil tray convenient for oil collecting
- ◆ Easy use to drain contained oil in low pressure
- ◆ Different adapter for Transmissions, Radiators, and Power Steering, etc

Specification:

- ◆ Tank capacity: 30Gallon
- ◆ Vacuum Pressure: 0.05Mpa
- ◆ Air Requirement: 0.6 – 0.8Mpa
- ◆ Fixed wheel: 7"
- ◆ Swivel castor: 4"

Item Number	Pcs/ctn	G.W./N.W.	Dimension	Q'ty/20'	Q'ty/40'	Remarks
XH-ODT-30-E	1	40/38kgs	52x50x101cm	88pcs	220pcs	

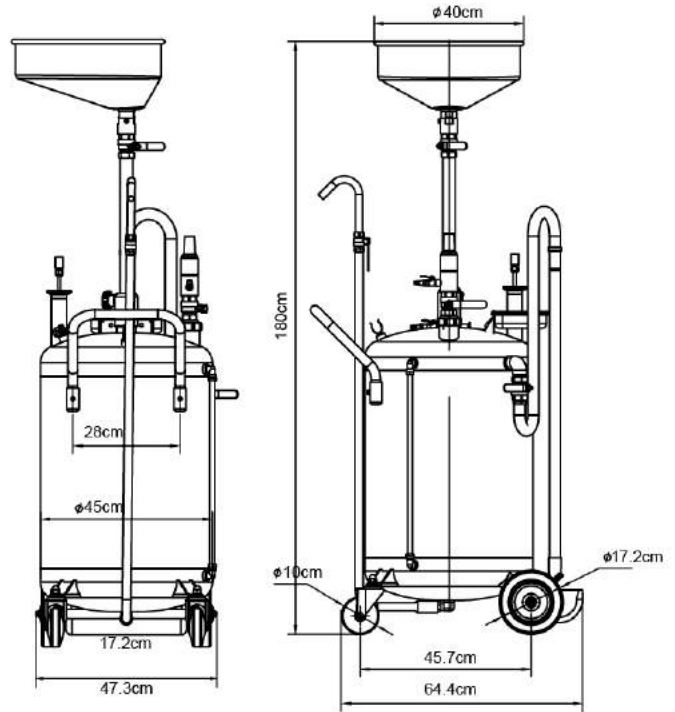

XH-ODT-30-E



Multi-functional Oil Drainer

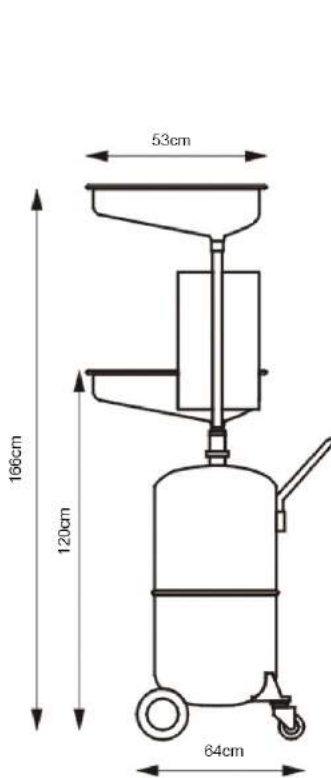

XH-ODT-E

Specification:

- ◆ Sucking speed:0.6-1.6L/min
- ◆ Collecting height: 1.85m
- ◆ Work pressure:7-8ba
- ◆ Tank capacity:65L
- ◆ Capacity of measuring cup:9L
- ◆ Draining pressure:0.5bar
- ◆ Length of suction pipe: 1.4m
- ◆ Length of drainpipe: 1.9m
- ◆ Total sucking capacity:40-50L
- ◆ Total weight:32kgs
- ◆ Exterior dimension:480x500x1850mm
- ◆ The multi-functional oil drainer has three functions: sucking,collecting and filling oil

Function:

- ◆ It easy used to drain oil in low pressure
- ◆ The oil drainer makes use of compressed air as power to produce vacuum in order to achieve its sucking function
- ◆ It is a safe ,convenient and quick machine .It never bring spark to you
- ◆ This machine is mainly used in garge,cars beautification,and cars producing,ect
- ◆ It can collect and fill oil for cars or other machines to achieve its fixed or movable working functions
- ◆ The movable body could meet your needs of using it in different places at any time
- ◆ The outside-layed cursor shows you the height of oil clearly
- ◆ The adjustable oil tray adapts to any types of cars
- ◆ Trashy oil can be suckede by minus pressure that produced by air,and also can be collectede by gravity
- ◆ Each machine is equipped with different specifications of nozzles
- ◆ The trasparent visual messuring cup is convenient to observe oil
- ◆ The tool tray can be disassembled

Notice:

- ◆ The temperature must be below 70-80 when draining oil
- ◆ The highest pressure is 0.5bar when draining oil
- ◆ Never use it for corrosive products

Item Number	Pcs/ctn	G.W./N.W.	Dimension	Q'ty/20'	Remarks
XH-ODT-E	1/2	25/23kgs	79x45.5x53cm	99pcs	
	1/2	11/8kgs	47.5x38.5x58.5cm		



65L Oil Drain Tank



XH-ODT

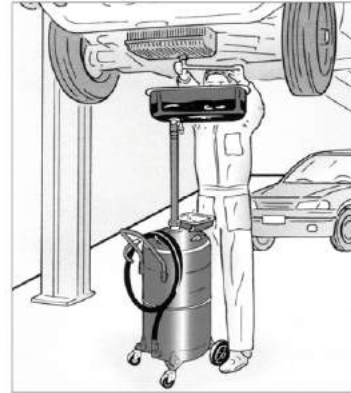
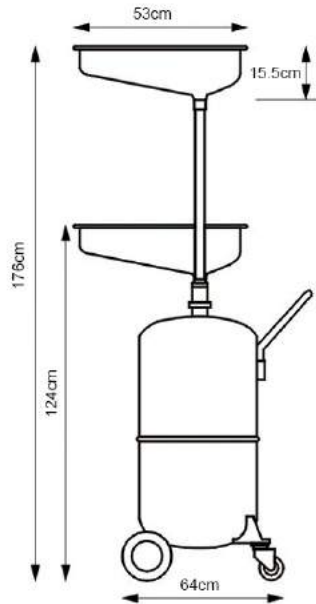

Function:

- ◆ Oil drain tank for collecting all kinds of trashy oil from auto, agriculture mechanism, ect

Specification:

- ◆ Tank capacity: 65litre
- ◆ Height & direction are adjustable for the oil tray
- ◆ Height air pressure 0.8bar
- ◆ 5" fixed axle wheel & 3" swivel casters

Item Number	Pcs/ctn	G.W./N.W.	Dimension	Q'ty/20'	Q'ty/40'	Remarks
XH-ODT	1	23/25kgs	75x42.5x54cm	165pcs	336pcs	

18 Gallon Oil Drainer Self Evacuating



XH-ODT-18-I

XH-ODT-18-II



Extends from 46" to 76"

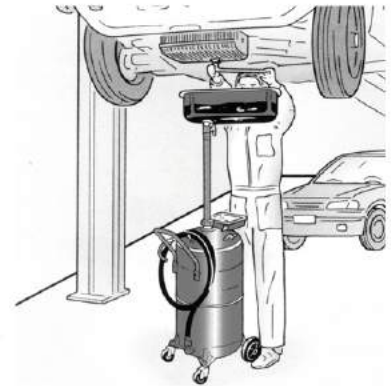
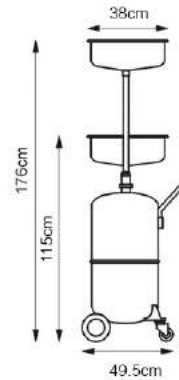

Specification:

- ◆ Heavy duty 15"x5.5"
- ◆ Receiver funnel
- ◆ Extends from 46" to 70"
- ◆ Two 6" fixed axle wheels
- ◆ Two swivel casters for maximum maneuverability
- ◆ 8" discharge hose with shut off valve
- ◆ Fluid level gauge is on the hose
- ◆ Air pressure valve

Item Number	Pcs/ctn	G.W./N.W.	Dimension	Q'ty/20'	Q'ty/40'HQ	Remarks
XH-ODT-18-I	1	26/23kgs	44x42x96cm	155pcs	370pcs	
XH-ODT-18-II	1	25/21kgs	93x45x52cm	155pcs	317pcs	

30 Gallon Oil Drain Tank



Specification:

- ◆ Tub height can be adjusted from 47-1/4" to 70-1/2" for draining fluids on vehicle lifts. Standard shop air pressure quickly empties used fluids from the storage tank
- ◆ Heavy duty 15-3/4" diameter drainage funnel with filter screen
- ◆ 27-1/2" long evacuation hose with 1/4"NPT air coupler and swivel casters
- ◆ Oil level sight gauge
- ◆ Working pressure: 7PSI
- ◆ Two swivel casters: 4"Dx1-1/5"W
- ◆ Wheels: 7"Dx1-1/2"W
- ◆ Capacity: 30 Gallons

Item Number	Pcs/ctn	G.W./N.W.	Dimension	Q'ty/20'	Q'ty/40'	Remarks
XH-ODT-30-1	1	36/33kgs	54x54x104cm	88pcs	220pcs	

XH-ODT-30-1

30 Gallon Oil Drain Tank

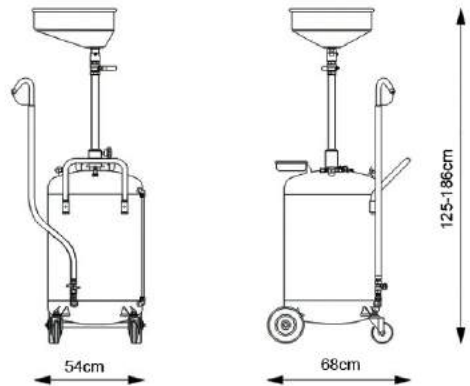

Specification:

- ◆ Tub height adjusts from 47-1/4" to 70-1/2" for draining fluids on vehicle lifts. Standard shop air pressure quickly empties used fluids from the storage tank
- ◆ Heavy duty 15-3/4" diameter drainage funnel with filter screen
- ◆ 27-1/2" long evacuation hose with 1/4"NPT air coupler and swivel casters
- ◆ Oil level sight gauge
- ◆ Working pressure: 7PSI
- ◆ Two swivel casters: 4"Dx1-1/5"W
- ◆ Wheels: 7"Dx1-1/2"W
- ◆ Capacity: 30 Gallons

Item Number	Pcs/ctn	G.W./N.W.	Dimension	Q'ty/20'	Q'ty/40'	Remarks
XH-ODT-30	1	35/33kgs	52x50x101cm	88pcs	220pcs	

XH-ODT-30

Bidirectional Hand Oil Pump



XH-GC

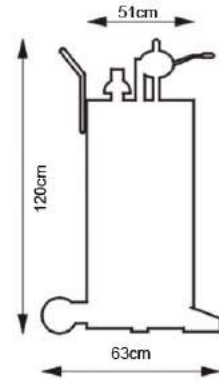
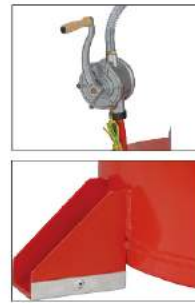

Function:

- ◆ The structure of this pump is easy compact, and convenient to use and maintain
- ◆ This pump has good self-sucking function. Never need to be filled liquid before using it, but only to speed up by hand
- ◆ The pump can self-lubricate when transporting liquid, so it is no need to be added lubrication in daily works
- ◆ This pump has bidirectional character, both for sucking and filling oil

Specification:

- ◆ Sucking speed: 13L/80R, 23r/min
- ◆ Weight: 22kg
- ◆ The two output mouths of pump body is NPT 3/4

Notice:

- ◆ This pump adapts to use gasoline, diesel oil ect, but is not suitable for that containing horniness grain, fibre or impurities

Item Number	Pcs/ctn	G.W./N.W.	Dimension	Q'ty/40'	Remarks
XH-GC	1	33/30kgs	96x53x52cm	192set	

Bidirectional Hand Oil Pump

Item Number	Pcs/ctn	G.W./N.W.	Dimension	Remarks
XH-OP	1	3/2kgs	15x17x20cm	

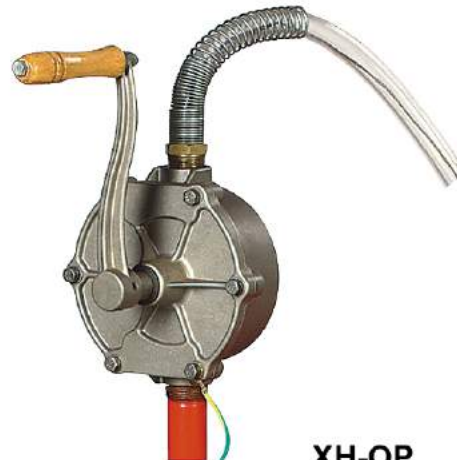

XH-OP

5G heavy-Duty portable Oil Drainer

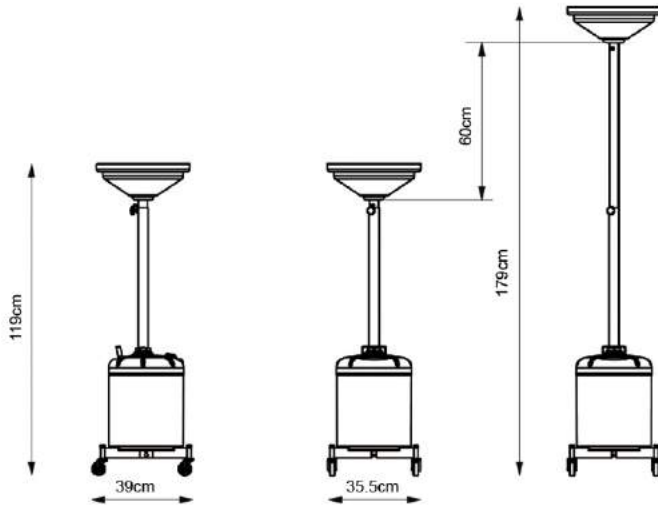

Specification:

- ◆ 5G galvanized steel container
- ◆ Large 14" heavy-duty polypropylene funnel
- ◆ Tube adjusts from 40" to 67"
- ◆ 3-3/4" capped grain for easy emptying
- ◆ High-gloss black enamel finish
- ◆ Wheel: 2"

Item Number	Pcs/ctn	G.W./N.W.	Dimension	Q'ty/20'	Q'ty/40'	Remarks
XH-ODT-5	1	10/8.5kgs	31x36x75.5cm	330pcs	660pcs	



XH-ODT-5

Facility Oil Drainer

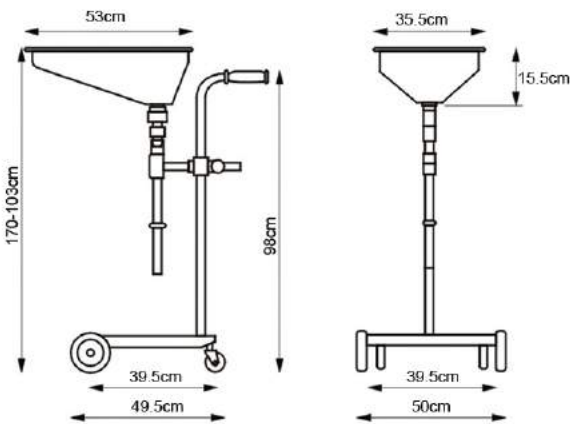

Function:

- ◆ Facility oil tray for collecting trashy oil

Specification:

- ◆ Facility Oil Tray for collecting trashy oil
- ◆ Height & operation direction adjustable
- ◆ 2.5" swivel caster

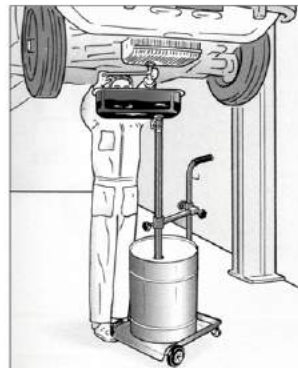

XH-ODT-F

Item Number	Pcs/ctn	G.W./N.W.	Dimension	Q'ty/20'	Q'ty/40'	Remarks
XH-ODT-F	1	15/13kgs	93x42.5x21.5cm	330pcs	660pcs	

Polyethylene Oil Drainer Tank with multi-fuction apply



XH-ODT-26



Specification:

- ◆ Large tank capacity:26gallon/100L
- ◆ Rubber Wheel:10"
- ◆ Swivel wheel:4"
- ◆ Bowl size:21L
- ◆ Max.Height:78.5"
- ◆ Min.Height:51.5"

Advantage:

- ◆ High-strength polyethylene reinforced tank,no corrosion, no denting,no swelling
- ◆ Compatible with virtually all used fluids:motor oil,transmission fluid,engine coolant,and etc
- ◆ Professional look and outstanding shop features together in one assenbly
- ◆ Evacuate easily with standard shop air

Item Number	Pcs/ctn	G.W./N.W.	Dimension	Q'ty/20'	Q'ty/40'	Remarks
XH-ODT-26	1	31.5/29.5kgs	55x54x99cm	75pcs	160pcs	

90L Multi-functional Oil Drainer

Function:

- ◆ Multi-function:oil sucking,oil collecting & oil filling
- ◆ Additional large oil tray convenient far oil collecting
- ◆ Easy use to drain oil in low pressure
- ◆ Transparent measuring cup for easy oil absorption
- ◆ Different type of nozzles is equipped for various condition

Specification:

- ◆ Sucking speed:0.6-1.6L/min
- ◆ Work pressure:7-8 Bar
- ◆ Collecting height:1.85m
- ◆ Tank capacity:90L
- ◆ Capacity of measuring cup:10L
- ◆ Length of suction pipe:1.5m
- ◆ Length of drainpipe:2.0m
- ◆ Total weight:37kgs
- ◆ Overall dimensions:500x500x1850
- ◆ Fixed wheel:7"
- ◆ Swivel castor:4"

Item Number	Pcs/ctn	G.W./N.W.	Dimension	Q'ty/40'	Remarks
XH-ODT90-E	1/2	29/27kgs	52x50x100cm	175pcs	
	1/2	12/10kgs	57x30x30cm		



XH-ODT90-E



CABINET SANDBLASTER



1200L Cabinet Sandblaster with Dual Working Position

CE

CABINET SANDBLASTER

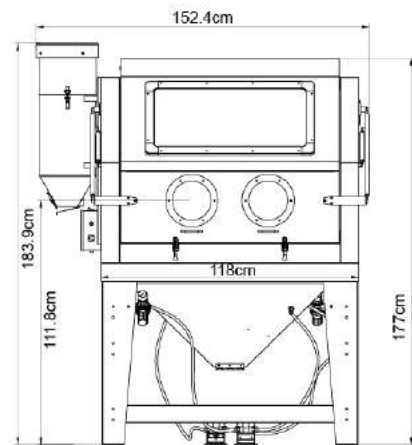
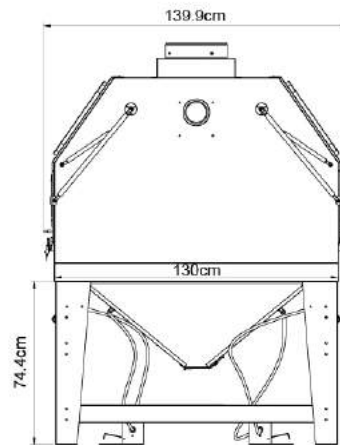

Specification:

- ◆ Natural rubber/vinyl blast gloves
- ◆ Perforated steel flooring-abrasive large particle-separating screen and clean-out door
- ◆ Powder coated inside and out
- ◆ Extra-rugged,heavy-duty production foot valve assembly,Built to blast with heavy steel housing and high-production brass flow valve
- ◆ Air regulator/gauge panel
- ◆ 12 gauge steel legs(16 gauge panels)
- ◆ Eliminating typical suction pick-up tubes and hoses,media metering valve puts our economy
- ◆ Series blast cabinets in a entirely different class from the competition
- ◆ External flourescent lighting system.Packed in wooden case
- ◆ Working Space: 1300*1180*850mm
- ◆ Air Requirement: 0.4~0.8MPA 60~125PSI
- ◆ Sand loading capacity: 32L

XH-SBC1200

Item Number	Pcs/ctn	G.W./N.W.	Dimension	Q'ty/20'	Q'ty/40'	Remarks
XH-SBC1200	1	245/200kgs	143x135x108cm	8pcs	16pcs	





XH-SBC420



XH-SBC420-II

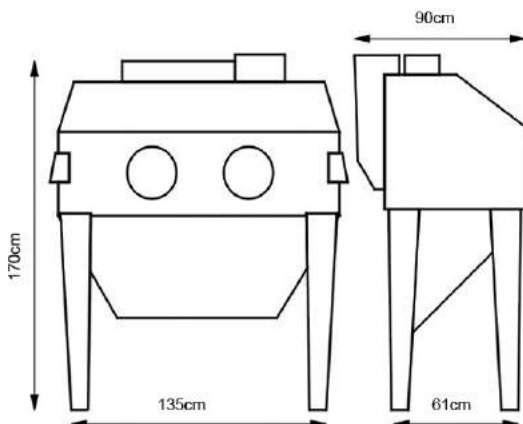

Specification:

- ◆ Natural rubber / vinyl blast gloves
- ◆ Preforated steel flooring-abrasive large particle-separating screen and clean-out door
- ◆ Powder coated inside and out
- ◆ Extra-rugged,heavy-duty production foot valve assembly.Built to blast with heavy steel housing and high-production brass flow valve
- ◆ Air regulator / gauge panel
- ◆ 14 gauge steel legs(16 gauge panels)
- ◆ Eliminating typical suction pick-up tubes and hoses ,media metering valve puts our economy
- ◆ Series blast cabinets in a entirely different class from the competition
- ◆ External flourescent lighting system.Packed in wooden case
- ◆ Overall dimension:135x90x170cm
- ◆ Work pressure range:90~125PSI

Item Number	Pcs/ctn	G.W./N.W.	Dimension	Q'ty/20'	Q'ty/40'	Remarks
XH-SBC420	1	147.5/113kgs	128x125x77cm	16pcs	36pcs	
XH-SBC420-II	1	160/124kgs	128x125x77cm	16pcs	36pcs	



XH-SBC990

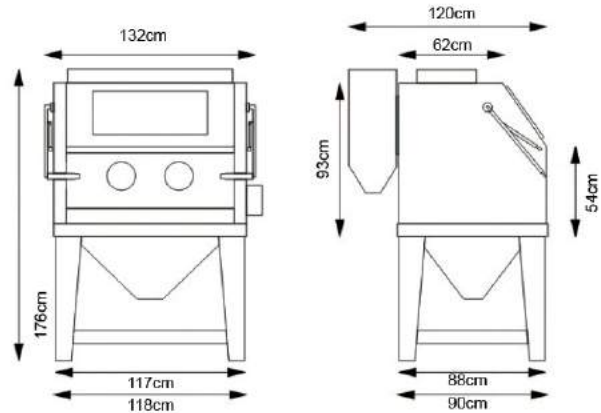

Specification:

- ◆ Natural rubber / vinyl blast gloves
- ◆ Preforated steel flooring—abrasive large particle—separating screen and clean-out door
- ◆ Powder coated inside and out
- ◆ Extra-rugged, heavy-duty production foot valve assembly. Built to blast with heavy steel housing and high-production brass flow valve
- ◆ Air regulator / gauge panel
- ◆ 12 gauge steel legs (16 gauge panels)
- ◆ Eliminating typical suction pick-up tubes and hoses, media metering valve puts our economy
- ◆ Series blast cabinets in a entirely different class from the competition
- ◆ External fluorescent lighting system. Packed in wooden case
- ◆ Overall dimension: 132x120x176cm
- ◆ Work pressure range: 90~125PSI

Item Number	Pcs/ctn	G.W./N.W.	Dimension	Q'ty/20'	Q'ty/40'	Remarks
XH-SBC990	1	198/160kgs	133x96x107cm	20pcs	40pcs	

Industrial-quality Pistol-grip Blasting Gun-foot-pedal Operated

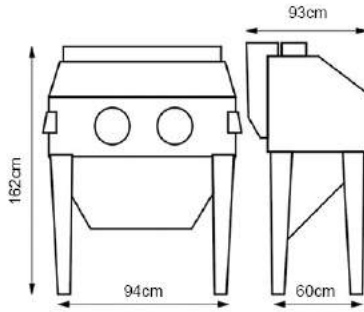

XH-SBC350

Specification:

- ◆ Natural rubber / vinyl blast gloves
- ◆ Preforated steel flooring—abrasive large particle—separating screen and clean-out door
- ◆ Powder coated inside and outside
- ◆ Air regulator / gauge panel
- ◆ 14 gauge steel legs(16 gauge panels)
- ◆ Eliminating typical suction pick-up tubes and hoses ,media metering
- ◆ Series blast cabinets in a entirely different class from the competition
- ◆ External flourescent lighting system.Packed in wooden case
- ◆ Overall dimension:104x93x162cm
- ◆ Work area:94.5x60.5x60.5cm
- ◆ Air pressure range:60~125PSI
- ◆ Sand capacity:40lbs
- ◆ Abrasive media:silica sand,glass beads,silicon carbide,emery,plastic sand,ect
- ◆ Power requirement:110V,60Hz or 230V,50Hz
- ◆ Output voltage:12V

Item Number	Pcs/ctn	G.W./N.W.	Dimension	Q'ty/20'	Q'ty/40'	Remarks
XH-SBC350	1	105/90kgs	128x99x76cm	16pcs	36pcs	

220L Vertical Cabinet Sandblaster



XH-SBC220-I



XH-SBC220-II

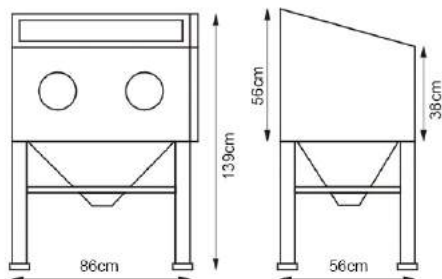

Function:

- ◆ Blast rust,corrosion and paint on large parts in a enclosed cabinet to keep dust off the floor and out of the air

Specification:

- ◆ Heavy steel construction,double door on the sides
- ◆ Transparent glass viewing window
- ◆ 40-80PSI @ 15-25CFM
- ◆ Working space:84x55x38cm
- ◆ Overall dimension:
 - a)XH-SBC220-I:138cm(H)x87cm(L)x63cm(W)
 - b)XH-SBC220-II:145cm(H)x87cm(L)x63cm(W)
- ◆ Electrical requirements of light:115V/230V
- ◆ XH-SBC220-II has two lights
- ◆ Maximum operation pressure:125PSI

Item Number	Pcs/ctn	G.W./N.W.	Dimension	Q'ty/20'	Q'ty/40'	Remarks
XH-SBC220-I	1	47/43kgs	96x62x62.5cm	63pcs	129pcs	
XH-SBC220-II	1	49/46kgs	96x62x68cm	63pcs	138pcs	

110L Cabinet Sandblaster

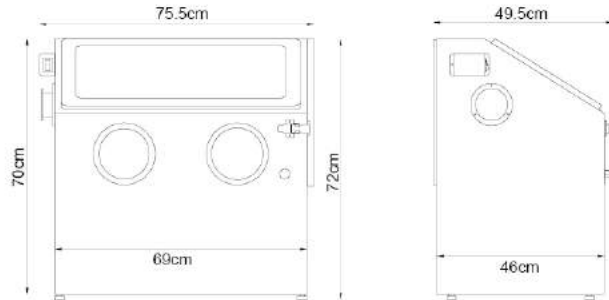

XH-SBC110



Specification:

- ◆ For use with glass beads, silica sand, alum oxide and more
- ◆ Air compressor delivery of 40-120PSI @ 15-25CFM
- ◆ Overall dimension: 75.5cm(L)x49.5cm(W)x72cm(H)
- ◆ Working space: 68.5cm(L)x45.5cm(W)x42cm(H)
- ◆ Sand Loading Capacity: 30L

Item Number	Pcs/ctn	G.W./N.W.	Dimension	Q'ty/20'	Q'ty/40'	Remarks
XH-SBC110	1	28/26.5kgs	77x51x73cm	84pcs	225pcs	

Benchtopsteel Cabinet Sandblaster



XH-SBC90

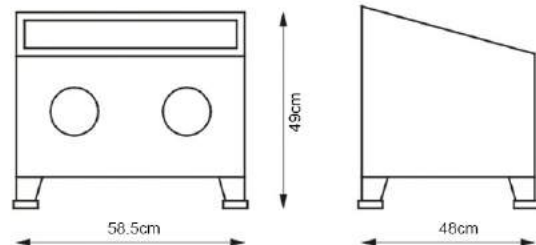

Function:

- ◆ Cleaning parts quickly and easily
- ◆ Through the sealed rubber glove parts, you control the high-efficiency air blast gun inside, directing 100 maximum PSI abrasive flow to clean parts FAST!

Specification:

- ◆ For use with glass beads, silica sand, alum oxide and more
- ◆ Red finish steel cabinet have a transparent plastic top door helps keep abrasive dry
- ◆ Air compressor delivery of 40-80PSI @ 5CFM
- ◆ Overall dimension: 58.5cm(L)x48cm(W)x49cm(H)
- ◆ Working space: 56cm(L)x46cm(W)x30.5cm(H)

Item Number	Pcs/ctn	G.W./N.W.	Dimension	Q'ty/20'	Q'ty/40'	Remarks
XH-SBC90	1	19/17.25kgs	64x51x52cm	160pcs	320pcs	

220L Cabinet Sandblaster-Knock Down

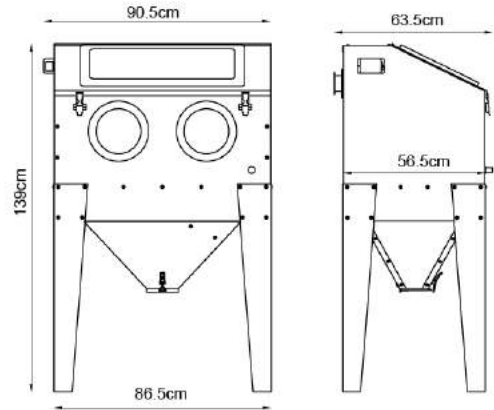

VOLUME COMPARASION

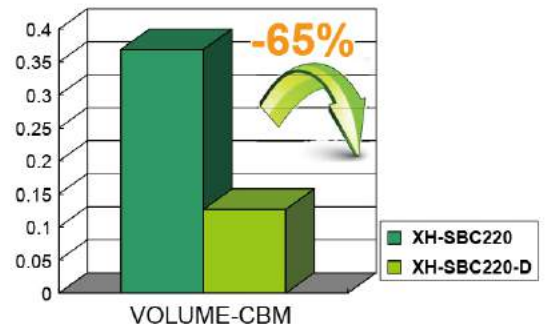

XH-SBC220-D

Item Number	Pcs/ctn	G.W./N.W.	Dimension	Q'ty/20'	Q'ty/40'	Remarks
XH-SBC220D	1	51/49kgs	87.5x71.5x16cm	216pcs	507pcs	

90L Cabinet Sandblaster-Knock Down



VOLUME COMPARASION

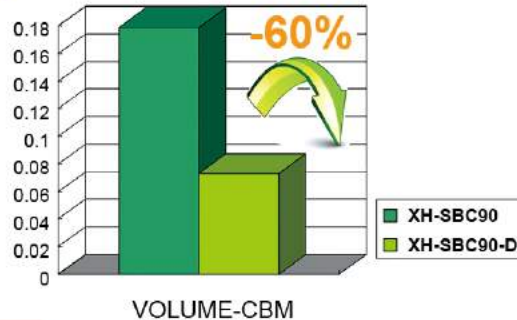

XH-SBC90-D

Item Number	Pcs/ctn	G.W./N.W.	Dimension	Q'ty/20'	Q'ty/40'	Remarks
XH-SBC90-D	1	18/17.25kgs	62x54x22cm	380pcs	902pcs	

VOLUME-CBM

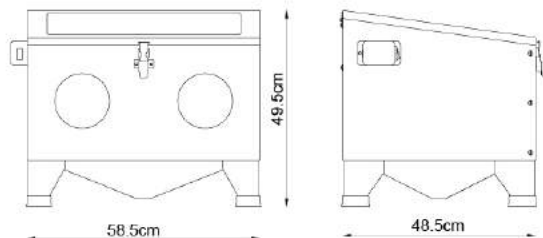

Function:

- ◆ Cleaning parts quickly and easily
- ◆ Through the sealed rubber glove parts, you control the high-efficiency air blast gun inside, directing 100 maximum PSI abrasive flow to clean parts FAST!

Specification:

- ◆ For use with glass beads, silica sand, alum oxide and more
- ◆ Red finish steel cabinet have a transparent plastic top door helps keep abrasive dry
- ◆ Air compressor delivery of 40-80PSI @ 5CFM
- ◆ Overall dimension: 58.5cm(L)x48cm(W)x49cm(H)
- ◆ Working space: 58cm(L)x48cm(W)x35cm(H)

Mini Sandblaster

CE



XH-SBC30

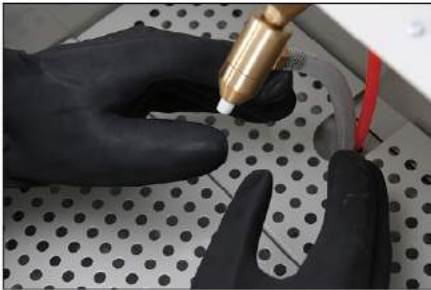

Specification:

- ◆ Heavy steel construction, no sand leakage
- ◆ Fluorescent lighting system for bright view
- ◆ Wearable blast gloves
- ◆ Sand capacity: 12lbs
- ◆ Ceramic nozzle 3.5mm
- ◆ Overall dimension: 475x370x370mm
- ◆ Working area: 410x310x200mm
- ◆ Work pressure: 80-115PSI & 7CFM
- ◆ Power requirement: 110V/60Hz, 230V/50Hz

Item Number	Pcs/ctn	G.W./N.W.	Dimension	Q'ty/20'	Q'ty/40'	Remarks
XH-SBC30	1	12.5/13.5kgs	49.5x39x41cm	354pcs	687pcs	

Art.Name:Dust Collector



SBC-DC



Specification:

- ◆ It can be matched with Sandblaster Cabinet (XH-SBC-1200, XH-SBC-990, XH-SBC420, XH-SBC350) convenient to collect dust

Item Number	Pcs/ctn	G.W./N.W.	Dimension	Remarks
XH-SBC-DC	1	9.4/9kgs	78x30x32cm	



ABRASIVE SANDBLASTER



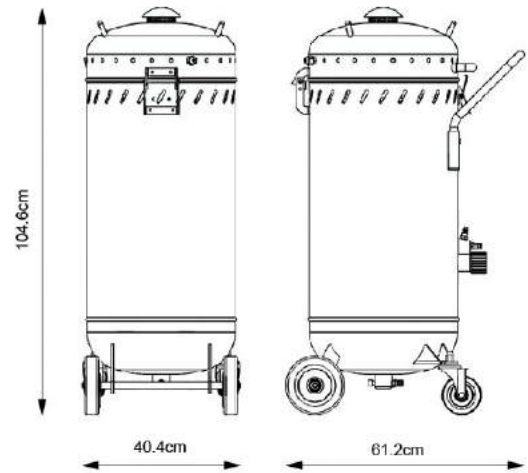

XH-SB28

Function:

- ◆ Built-in vacuum eliminates the need for breathing apparatus
- ◆ Separates abrasive from debris
- ◆ Cuts cleanup time

Specification:

- ◆ Use with most blast media including silica, shot, and shell
- ◆ Removable dust container
- ◆ 6" diameter rear wheels for easy transport
- ◆ Air consumption: 6-22.5CFM @ 115PSI
- ◆ Motor power: 1200w
- ◆ Air inlet: 1/22" - 18Npt
- ◆ Tank size: 41"(H)x15"(I.D)



Item Number	Pcs/ctn	G.W./N.W.	Dimension	Q'ty/20'	Q'ty/40HQ	Remarks
XH-SB28	1	35/32kgs	102x46x51.5cm	110pcs	275pcs	

20 Gallon Sandblaster

CE



XH-SB20-I

XH-SB20-II

Item Number	Pcs/ctn	G.W./N.W.	Dimension	Q'ty/20'	Q'ty/40'	Remarks
XH-SB20-I	1	23/21kgs	88x46x42cm	160pcs	329pcs	
XH-SB20-II	1	25/23kgs	88x46x42cm	160pcs	329pcs	



Function:

- ◆ Sandblast parts before welding or painting
- ◆ Replaceable ceramic tips in nozzle prolonging service life
- ◆ Use aluminum oxide or glass beads for cleaning

Specification:

- ◆ Heavy-duty all steel construction
- ◆ Tank volume:20Gallon
- ◆ Air Consumption:6-25CFM
- ◆ Overall dimension:92cm(H)x78cm(L)x38cm(W)
- ◆ Equipped with new sandblast gun and concerned necessary parts
- ◆ Hose length:8feet
- ◆ Working pressure:60-125PSI

10 Gallon Sandblaster

CE



XH-SB10

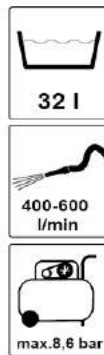

Function:

- ◆ Pressurized design 30% more sandblasting power than siphon units
- ◆ Provides more abrasive when you need truly efficient performance

Specification:

- ◆ Equipped with a nozzle and shut-off valve, pressure gauge, ceramic nozzle, 2.5mm, hose, filling funnel, watertrap, 6" rubber wheels and can vas hood
- ◆ Tank Dimensions: 12"Diameter, 2'Length
- ◆ Overall dimension: 83cm(H)x48cm(L)x33cm(W)
- ◆ Hose length: 2.5M
- ◆ Working pressure: 60-125PSI & 6-25CFM
- ◆ Tank volume: 32L

Item Number	Pcs/ctn	G.W./N.W.	Dimension	Q'ty/20'	Q'ty/40HQ	Remarks
XH-SB10	1	19/17kgs	77x42x38cm	233pcs	500pcs	

5 Gallon Sandblaster

CE



XH-SB5



Function:

- ◆ Pressurized design 30% more sandblasting power than siphon units
- ◆ Provides more abrasive when you need truly efficient performance

Specification:

- ◆ Equipped with a nozzle and shut-off valve, pressure gauge, ceramic nozzle, 2.5mm, hose, filling funnel, watertrap, 6" rubber wheels and can vas hood
- ◆ Tank Dimensions: 10" Diameter, 15" Length
- ◆ Overall dimension: 83cm(H)x48cm(L)x29cm(W)
- ◆ Hose length: 2.5M
- ◆ Working pressure: 60-125PSI & 6-25CFM
- ◆ Tank volume: 17L
- ◆ Air consumption: 6-25CFM

Item Number	Pcs/ctn	G.W./N.W.	Dimension	Q'ty/20'	Q'ty/40'	Remarks
XH-SB5	1	15/13kgs	62x42x36cm	294pcs	636pcs	

10/20 Gallon Roll-About Pressure Sandblaster

CE



XH-RA20

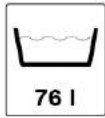

XH-RA10

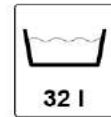

Specification:

- ◆ Has safety pressure release valve, 3/8in. Brass valves for air throttling and sand metering
- ◆ Work pressure: 60 to 125 PSI
- ◆ Baked enamel finish
- ◆ Heavy duty 3/8in, 8-ft, hose has carbon steel shut off valve and 4 inter changeable nozzles
- ◆ Hood has instruction are in stock
- ◆ Hose length: 8ft
- ◆ Tank dimension: 12- 1/2" dia, 27" length
- ◆ Pressure gauge indicator: 0~230PSI
- ◆ Requird compressed air system(not included): 2HP compressor with 3/8" diameter air hose
- ◆ Recommended media type: glass bead, silicon carbide, alumina, walnut shell, brass bead
- ◆ Recommended use: use with 80, 100, 120 grit media, at 60PSI, with 3/32". Nozzle for best results(run time: 45minutes with 90lbs, media
- ◆ Water trap type: push button to drain
- ◆ Accessories: 3/32", 7/64", 1/8", 9/64" nozzles

Item Number	Pcs/ctn	G.W./N.W.	Dimension	Q'ty/40'	Remarks
XH-RA10	1	23/21kgs	75x33x38cm	560pcs	
XH-RA20	1	27.5/25.5kgs	82.5x35x43.5cm	420pcs	



50/90 LBS Siphon Feed Sandblaster

Specification:

- ◆ Sand Grade Type: up to 60 grit
- ◆ Abrasive material: aluminum oxide, garnet powder, glass bead
- ◆ Drum capacity: 50/90lbs
- ◆ Sand capacity: 22.6/40kg
- ◆ Operating pressure: 60-120PSI
- ◆ Flow rate req: 10-16CFM
- ◆ Compressor size HP (minimum): 3
- ◆ Gun inlet size: 3/8" hose adaptor fitted
- ◆ Air inlet hose diameter: 3/8" (10mm)
- ◆ Nozzle sizes: 4mm, 5mm, 6mm, 7mm, (ceramic)

Item Number	Pcs/ctn	G.W./N.W.	Dimension	Q'ty/40'	Remarks
XH-SFSB(50L)	1	7.5/5.5kgs	51x33x35cm	1001pcs	
XH-SFSB(90L)	1	9/7kgs	77x33x35cm	668pcs	



XH-SFSB(50L)

XH-SFSB(90L)

Dual Blaster for Soda and Abrasive



XH-DSB10

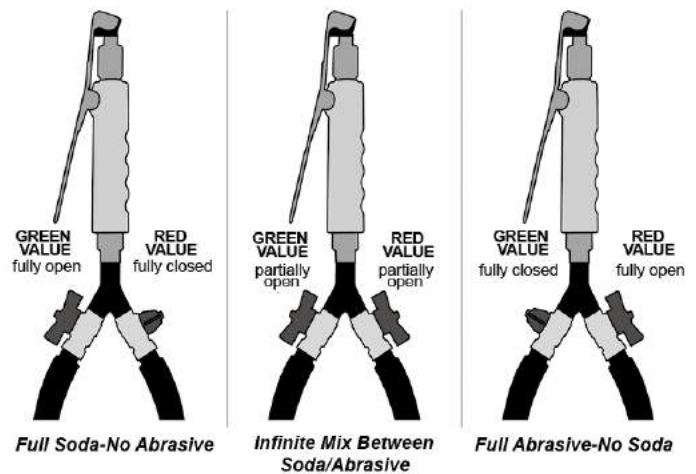

Specification:

- ◆ Tank volume-----10 gallons/100 lbs, abrasive or 75 lbs, of soda media
- ◆ Hose length -----8 ft x 1/2" i.d.
- ◆ Working pressure-----60-125 psi
- ◆ Air consumption-----6-25 cfm

Item Number	Pcs/ctn	G.W./N.W.	Dimension	Q'ty/20'	Q'ty/40'	Remarks
XH-DSB10	1	38/33kgs	76x73x38cm	135pcs	279pcs	

Hand Held Sandblaster



HSB-I



HSB-II

Specification:

- ◆ All new ergonomic legerity function
- ◆ Always wear eye protection and protective clothing equipment to avoid injuries
- ◆ Please pay attention,that the operation pressure never exceed over 6,7 bar
- ◆ Disconnect the tool from the air-supply befor changing accessories or when nothing in use
- ◆ Light weight plastic gun body
- ◆ Tank 0.9L capacity
- ◆ Operating pressure 90PSI
- ◆ Air Inter:1/4"NPT female
- ◆ 4 Extra functional nozzles

Item Number	Pcs/ctn	G.W./N.W.	Dimension	Q'ty/20'	Q'ty/40'	Remarks
HSB-I	6	7.5/5kgs	58x35x28cm	3100pcs	6200pcs	
HSB-II	6	5/3.5kgs	58x35x26cm	3100pcs	6200pcs	

Sanding Hood For Sandblast Tank



XH-SBH



Item Number	Pcs/ctn	G.W./N.W.	Dimension	Q'ty/40'	Remarks
XH-SBH	6	6.5/5kgs	47x30x56cm	4200pcs	



Item Number	Pcs/ctn	G.W./N.W.	Dimension	Remarks
1:XH-SB10Nozzles	120 sets/ctn	5.4/5.9kgs	63x30x15cm	SIZE:2/2.5/3/3.5mm
2:XH-SB10Pad	120 sets/ctn	3.1/3.6kgs	63x30x15cm	
3:XH-90Nozzles	120 sets/ctn	8.67/9.17kgs	63x30x15cm	SIZE:5/6/7mm
4:XH-90PE	60 sets/ctn	11.8/12.5kgs	66x47x37cm	5PCS/SETS
XH-220PE		15.73/16.43kgs	66x47x32cm	

Sand Blast Gun

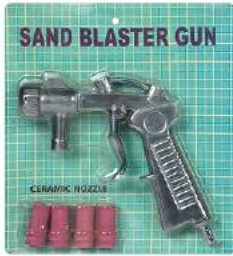

SBCG-I

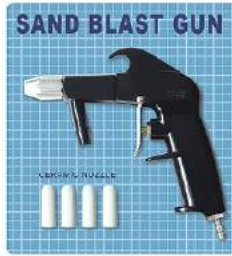

SBCG-II



Specification:

- ◆ 4Nozzles:4mm,5mm,6mm,7mm

Item Number	Pcs/ctn	G.W./N.W.	Dimension	Q'ty/20'	Remarks
XH-SBCG-I	24	13.5/12kgs	50x45x21cm	14520pcs	
XH-SBCG-II	24	14.5/13kgs	50x45x21cm	14520pcs	

New Type Sandblast Gun



XH-SBG

Specification:

- ◆ Just one-gush on, more convenience operation
- ◆ Air inlet 1/4 n.p.t:Extra nozzles
- ◆ Air inlet key wrench
- ◆ 4 Nozzles:2mm,2.5mm,3mm,3.5mm

Item Number	Pcs/ctn	G.W./N.W.	Dimension	Q'ty/20'	Remarks
XH-SBG	24	13.5/12kgs	42x28x35cm	14976pcs	

Abrasive Blasting Deadman Valve



XY-103

Specification:

- ◆ Safty shutoff deadman valve with 4/5/6/7mm

Item Number	Pcs/ctn	G.W./N.W.	Dimension	Remarks
XY-103	20	38/36kgs	42x28x30cm	

Soda Blast Retro Fit Kit



Specification:

- ◆ Soda Blast Retro Fit Kit to convert any pressure blaster into a soda blaster

Item Number	Pcs/ctn	G.W./N.W.	Dimension	Remarks
XY-SK	20	19/18kgs	39x35.5x33cm	



XY-SK

Tear Down TABLE

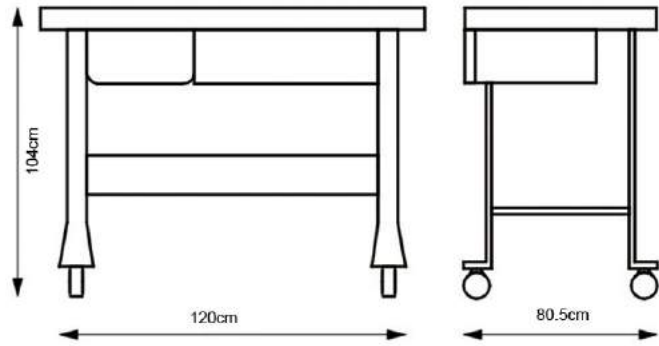

Item Number	Pcs/ctn	G.W./N.W.	Dimension	Q'ty/20'	Q'ty/40'	Remarks
XH-TT	1/3	67/61kgs	121x82x9cm 88x72x21cm 55x54x20cm	90sets	185sets	
	1/1	67/61kgs	143.5x83x34.5cm	66sets	122sets	

Specification:

- ◆ Tear-down table heavy 14 gauge unit serves as a combination Tear-down table
- ◆ Work bench and tool storage facility
- ◆ 48"x23" table top features a 3/4" rim to contain all liquids when working on engines, hydraulic systems and transmissions
- ◆ Fluid drains into a special removable polyethylene container
- ◆ Includes heavy-duty 4" casters (rigid and 2 locking swivel, tool storage drawer on steel ball bearing track)
- ◆ 1000lbs load capacity

Combination Cleaning TABLE



XH-TT-1

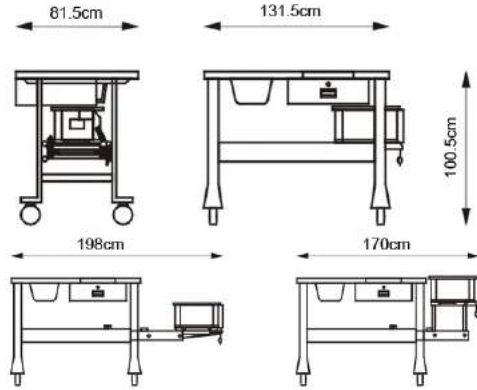

Specification:

- ◆ Heavy 14 gauge unit serves as a combination cleaning table
- ◆ Work bench and tool storage facility with parts cleaning function
- ◆ 48"x23" table top features a 3/4" rim to contain all liquids when working on engines, hydraulic systems and transmissions
- ◆ Fluid drains into a special removable polythylene container
- ◆ Includes heavy-duty 4" casters (rigid and 2 locking swivel, tool storage drawer on steel ball bearing track)

Item Number	Pcs/ctn	G.W./N.W.	Dimension	Q'ty/20'	Q'ty/40'	Remarks
XH-TT-1	1	120/86kgs	143x83x62cm	33sets	66sets	

Combination Cleaning TABLE

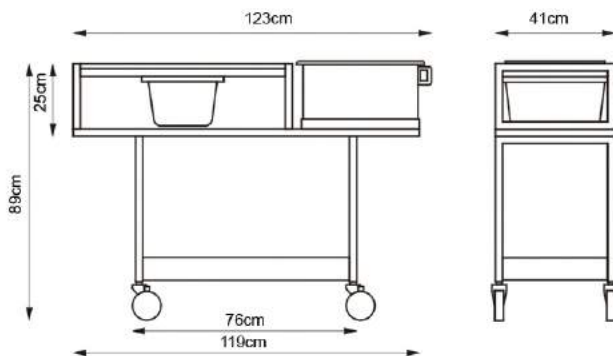

XH-TT-II

Specification:

- ◆ Heavy 14 gauge unit serves as a combination cleaning table
- ◆ Work bench and tool storage facility
- ◆ 27.5"x16" table top features a 3/4" rim to contain all liquids when working on engines, hydraulic systems and transmissions
- ◆ Fluid drains into a special removable polythylene container
- ◆ With 1PC3-1/2gallon parts washer

Item Number	Pcs/ctn	G.W./N.W.	Dimension	Q'ty/20'	Q'ty/40'	Remarks
XH-TT-II	1	30/27kgs	123x45x30cm	154sets	322sets	

2 Shelf Service Cart With Locking Lid & 2-drawer Chest



XH-TB-1

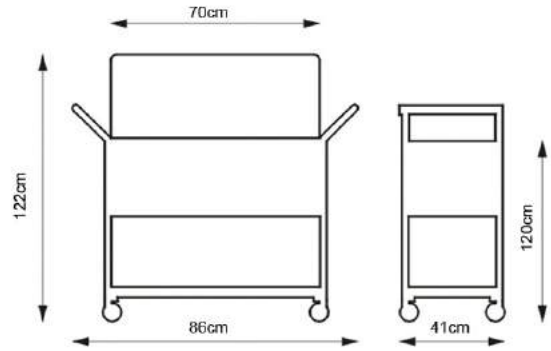

Specification:

- ◆ Heavy-duty swivel casters(2-lockable)
- ◆ Electric static powder coating resists rust & scratches
- ◆ Top cover & tool box keyed alike so one key opens both

Item Number	Pcs/ctn	G.W./N.W.	Dimension	Q'ty/40'	Remarks
XH-TB-1	1	42/38kgs	92x50x42cm	282pcs	

2 Shelf Service Cart



XH-TB-2

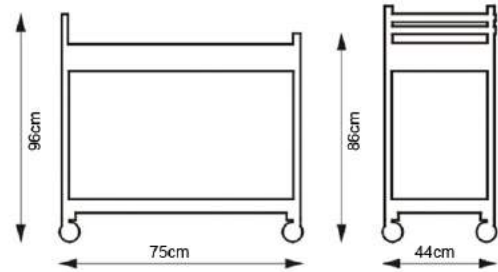

Specification:

- ◆ 2 Shelf service cart
- ◆ 29-1/2" w x 28" h x 17-1/4" d
- ◆ Heavy gauge steel construction.350lb load capacity
- ◆ Large swivel casters

Item Number	Pcs/ctn	G.W./N.W.	Dimension	Q'ty/40'	Remarks
XH-TB-2	1	17/14.5kgs	87x44x15cm	1005pcs	

165PSI Multi Purpose Air Tank 7Gallon/26.5L



XH-AT01



COMPRESOR
COMPRESSEUR



7G
AIR TANK
RÉSERVOIR D'AIR DE 26,5 L
TANQUE DE AIRE DE 26,5 L



AIR TOOL
OUTIL PNEUMATIQUE
HERRAMIENTA
NEUMÁTICA

Specification:

- ◆ Pressure capacity:165PSI
- ◆ Tank capacity:7 gal
- ◆ Easy-to-read gauges and 48 inch high-pressure hose
- ◆ Accepts air chuck or schrader valve for inflation

Item Number	Pcs/ctn	G.W./N.W.	Dimension	Q'ty/20'	Q'ty/40'	Remarks
XH-AT01	1	10.5/9kgs	68x26.5x34.5cm	440pcs	935pcs	

Right Angle Drill



Specification:

- ◆ For hand or power drill uses, including portable electric drills, sanding or buffing attachments (and other drill accessories)
- ◆ This 90 degree drive attachment allows you to drill in tight corners or at awkward angles
- ◆ Lubricated steel gear: 1:1 gear ratio
- ◆ High impact plastic body: 3/8" 24THD
- ◆ 1/16"–3/8 Cap; 1.5mm–10mm Cap

XH-RAD

Item Number	Pcs/ctn	G.W./N.W.	Dimension	Q'ty/20'	Q'ty/40'	Remarks
XH-RAD	24	17.5/16kgs	61x34.5x26.5cm	1200pcs	2400pcs	

Vehicle Dollies



XH-VD2

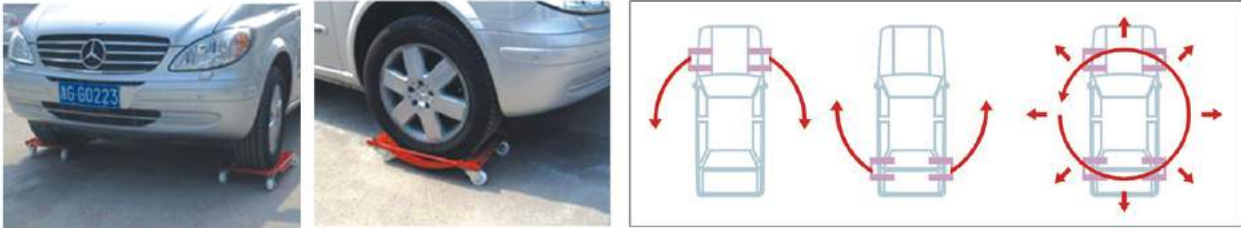

Function:

- ◆ Using for moving vehicle

Specification:

- ◆ 1)Load limit 1000lbs each
- ◆ 2)Nylon or iron cast wheel available

Item Number	Pcs/ctn	G.W./N.W.	Dimension	Q'ty/20'	Q'ty/40'	Remarks
XH-VD2	1	17.5/16kgs	62x41.8x18cm	600pcs	1244pcs	

Fish Tape



Specification:

- ◆ Cable length 50ft /15m;100ft /3m; 20ft /60m
- ◆ High-impact plastic case
- ◆ Durable nylon handle

Function:

- ◆ For pulling electrical or telecommunication wire

Item Number	Pcs/ctn	G.W./N.W.	Dimension	Q'ty/20'	Q'ty/40'	Remarks
XH-FT50'	12	13/11.5kgs	43x23x27.5cm	13200pcs	26400pcs	
XH-FT100'	6	13/11kgs	39x33x25cm	5922pcs	12000pcs	
XH-FT200'	6	20/15kgs	39x33x25cm	5922pcs	12000pcs	

Welding Cart



XH-WC



XH-WC-1

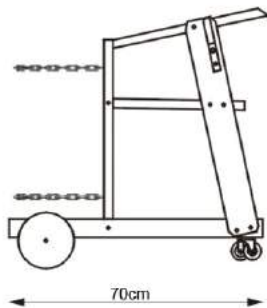
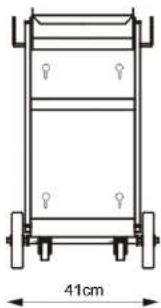

Specification:

- ◆ Sturdy formed steel construction
- ◆ Tilted top shelf for easier access to welder controls
- ◆ Includes two shelves under the welder to extra storage and two safety chains to keep gas cylinder securely in place
- ◆ Maximum weight capacity :100lbs
- ◆ Dimensions:top tray:17.25"L x 11.4"W
- ◆ Middle tray:15.5"L X 11.4"W
- ◆ Bottom tray:27.8"L X 11.4"W
- ◆ Two swivel castors on front:3"D X 0.75"W
- ◆ Rear fixed wheels:7.25"D x 1.5"W
- ◆ Overall dimensions:27.75"L X 16.5"W X 30.5"H
- ◆ Weight:26.4lbs

Item Number	Pcs/ctn	G.W./N.W.	Dimension	Q'ty/20'	Q'ty/40'	Remarks
XH-WC	1	13/11kgs	71x31x11cm	1140pcs	2280pcs	
XH-WC-1	2	12/11kgs	46x30x36.5cm	204pcs	430pcs	
		13.5/12.5kgs	71x31x11cm			

Welding Cart With Tool Box



XH-WC-2



Specification:

- ◆ Wild top table suit for different kinds welder
- ◆ 4 drawers and 3 shelves for extra tool-storage
- ◆ Maximum weight capacity :300lbs
- ◆ Front wheels:3"
- ◆ Rear wheels:8"
- ◆ Overall Size:123x77x85cm



XH-WC-3



Specification:

- ◆ 4 drawers and 3 shelves for extra tool-storage
- ◆ Side hook especially designed for welder wire
- ◆ Maximum weight capacity :150lbs
- ◆ Front wheels:3"
- ◆ Rear wheels:7"
- ◆ Overall Size:73x45x86cm

Item Number	Pcs/ctn	G.W./N.W.	Dimension	Q'ty/20'	Q'ty/40'	Remarks
XH-WC-2	1	71/67kg	94x54x77cm	70pcs	148pcs	
XH-WC-3	1	40/38kg	58.5x42x78cm	147pcs	305pcs	

Welding Cart



XH-WC-4

Specification:

- ◆ Sturdy formed steel construction
- ◆ Tilted shelf for easy welder control
- ◆ Front wheels:4"
- ◆ Rear wheels:8"



XH-WC-5

Specification:

- ◆ Sturdy formed steel construction
- ◆ Tilted shelf for easy welder control
- ◆ Front wheels:6"
- ◆ Rear wheels:10"



XH-WC-6

Specification:

- ◆ Sturdy formed steel construction



XH-WC-7

Specification:

- ◆ Sturdy formed steel construction
- ◆ Tilted shelf for easy welder control



Item Number	Pcs/ctn	G.W./N.W.	Dimension	Q'ty/20'	Q'ty/40'	Remarks
XH-WC-4	1	16.5/15kg	89x40.5x20cm	400pcs	828pcs	
XH-WC-5	1	24.5/23kg	39.5x88x20.5cm	400pcs	828pcs	89x40.5x20
XH-WC-6	1	12.1/11.5kg	78.5x34x9cm	1166pcs	2416pcs	
XH-WC-7	1	12.8/12kg	80x44x9cm	883pcs	1830pcs	79.5x43x8.5cm

Oil Dispensing Equipment



PT.NO.62063

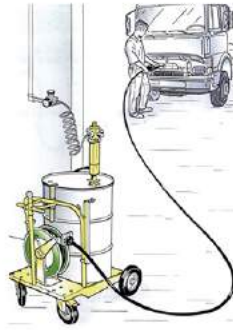

Specification:

- ◆ Suitable for 180–220kg drum
- ◆ Combine by follows:
hose reel can be fixed on the heavy duty dolly(PT.NO.64001)
hose of hose reel(PT.NO.82110) is 33' length & 1/2" diameter
oil pump(PT.NO.50194)
connector(PT.NO.66892)
hose 5'-1/4" connecting the pump and hose reel
oil gun with one way nipple pulg,oil control handle and delivery hose(PT.NO.66860)

Heavy Duty Grease Dispensing Equipment



PT.NO.64000

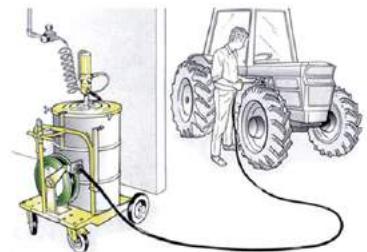

Specification:

- ◆ Suitable for 180–220kg drum
- ◆ Combine by follows:
hose reel can be fixed on the heavy duty dolly(PT.NO.64001)
hose of hose reel(PT.NO.82110) is 33' length & 1/2" diameter
grease pump(PT.NO.61094)
connector(PT.NO.66892)
hose 5'-1/4" connecting the pump and hose reel
triple swivel joint(PT.NO.66663)
grease gun with one way nipple pulg
grease control handle and delivery hose(PT.NO.66860)
drum cover diameter:600mm(PT.NO.65600)
drum out diameter:550mm–600mm
follower plate diameter:585mm(PT.66585)
drum inner diameter:540mm–580mm

Grease Dispensing Equipment



PT.NO.64054

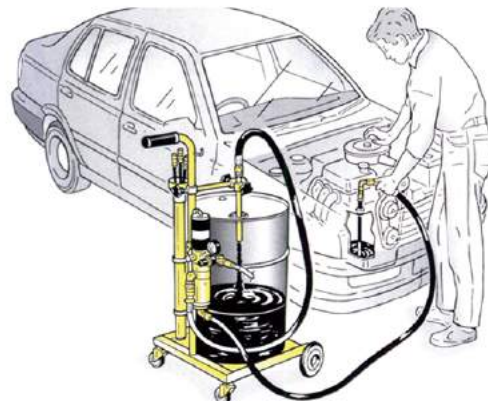

Specification:

- ◆ dolly-type grease dispensing equipment PT.NO.64054
- ◆ suit for 50–60kg drum
- ◆ with 400mm diameter's follower plate(PT.NO.66400)
- ◆ inner diameter 360mm–390mm

High Pressure Air Operated Grease Pump



PT.NO.63213

Specification:

- ◆ with 13kg capacity dolly drum
- ◆ with one air operated grease pump, neat design
- ◆ easy to take and operating in the car and machine
- ◆ the surface is treated through powder coated
- ◆ nice appearance and long service life
- ◆ witch combine by follows:
rate:60:1 air operated grease pump
240mm diameter follower plate(PT.NO.66240)
spring of follower plate
connector(PT.NO.66892)
dispensing grease hose 13' length & 1/4" daimeter(PT.NO.91404)
grease gun with one metal delivery tube(PT.NO.66888)
oil-water separator



Item Number	Pcs/ctn	G.W./N.W.	Dimension	Q'ty/20'	Q'ty/40'	Remarks
63213	1	13/11.5kg	90x36x40cm	190	390	
64054	1	15/13kg	93x42.5x21.5cm	374	748	

Air Operated Grease Pump



61094 61074 61048 50194 50174 50148

PT.NO.61048

- ◆ Rate:60:1, suitable for 20–30kg drum
- ◆ grease distribute automatically at 500g/min when pressure reaches to 6 bar
- ◆ air inlet connection:1/4" grease outlet connection:1/4"
- ◆ suction tube length:410mm suction tube diameter:30mm

PT.NO.61074

- ◆ Rate:60:1, suitable for 50–60kg drum
- ◆ grease distribute automatically at 500g/min when pressure reaches to 6 bar
- ◆ air inlet connection:1/4" grease outlet connection:1/4"
- ◆ suction tube length:740mm suction tube diameter:30mm

PT.NO.61094

- ◆ Rate:60:1, suitable for 180–200kg drum
- ◆ grease distribute automatically at 500g/min when pressure reaches to 6 bar
- ◆ air inlet connection:1/4" grease outlet connection:1/4"
- ◆ suction tube length:940mm suction tube diameter:30mm

PT.NO.50148

- ◆ Rate:5:1, suitable for 20–30kg drum
- ◆ oil distribute automatically at 8L/min when pressure reaches to 6 bar
- ◆ air inlet connection:1/4" grease outlet connection:1/4"
- ◆ suction tube length:410mm suction tube diameter:40mm

PT.NO.50174

- ◆ Rate:5:1, suitable for 50–60kg drum
- ◆ oil distribute automatically at 8L/min when pressure reaches to 6 bar
- ◆ air inlet connection:1/4" grease outlet connection:1/4"
- ◆ suction tube length:740mm suction tube diameter:40mm

PT.NO.50194

- ◆ Rate:5:1, suitable for 180–200kg drum
- ◆ oil distribute automatically at 8L/min when pressure reaches to 6 bar
- ◆ air inlet connection:1/4" grease outlet connection:1/4"
- ◆ suction tube length:940mm suction tube diameter:40mm

Heavy Duty Dolly



PT.NO.64001



Specification:

Entirely galvanized or powder coated, suitable for handling 180–220 drums. Equipped with 4(2 fixed and 2 castors) very smooth wheels that make them extremely easy to handle. Their compact size ensures perfect integration in the workplace and their modularity enables compact packing for easy storage. Equipped with clamping device and adjustable side support for hooking the control handle and hose or other accessories

Item Number	Pcs/ctn	G.W./N.W.	Dimension	Q'ty/20'	Q'ty/40'	Remarks
61048	1	5.6/4.6kg	89x12x12cm	2100	4300	
61074	1	6.2/5.2kg	109x12x12cm	1700	3600	
61094	1	6.8/5.8kg	129x12x12cm	1450	3000	
50148	1	6.3/5.3kg	91x12x12cm	2050	4250	
50174	1	7.0/6.0kg	111x12x12cm	1650	3500	
50194	1	7.6/6.6kg	131x12x12cm	1400	2900	
64001	1	28/25kg	94x61x12cm	390	810	

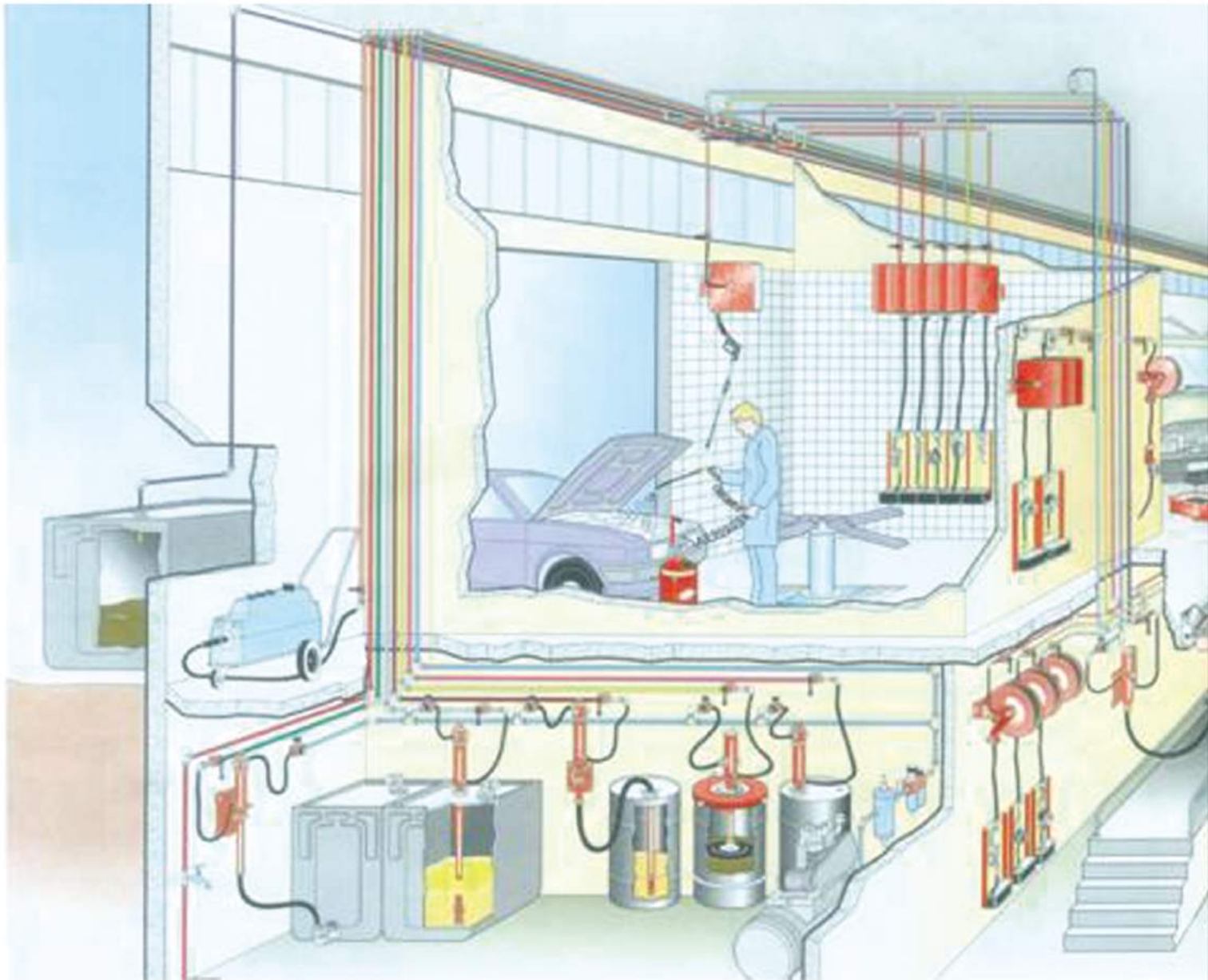

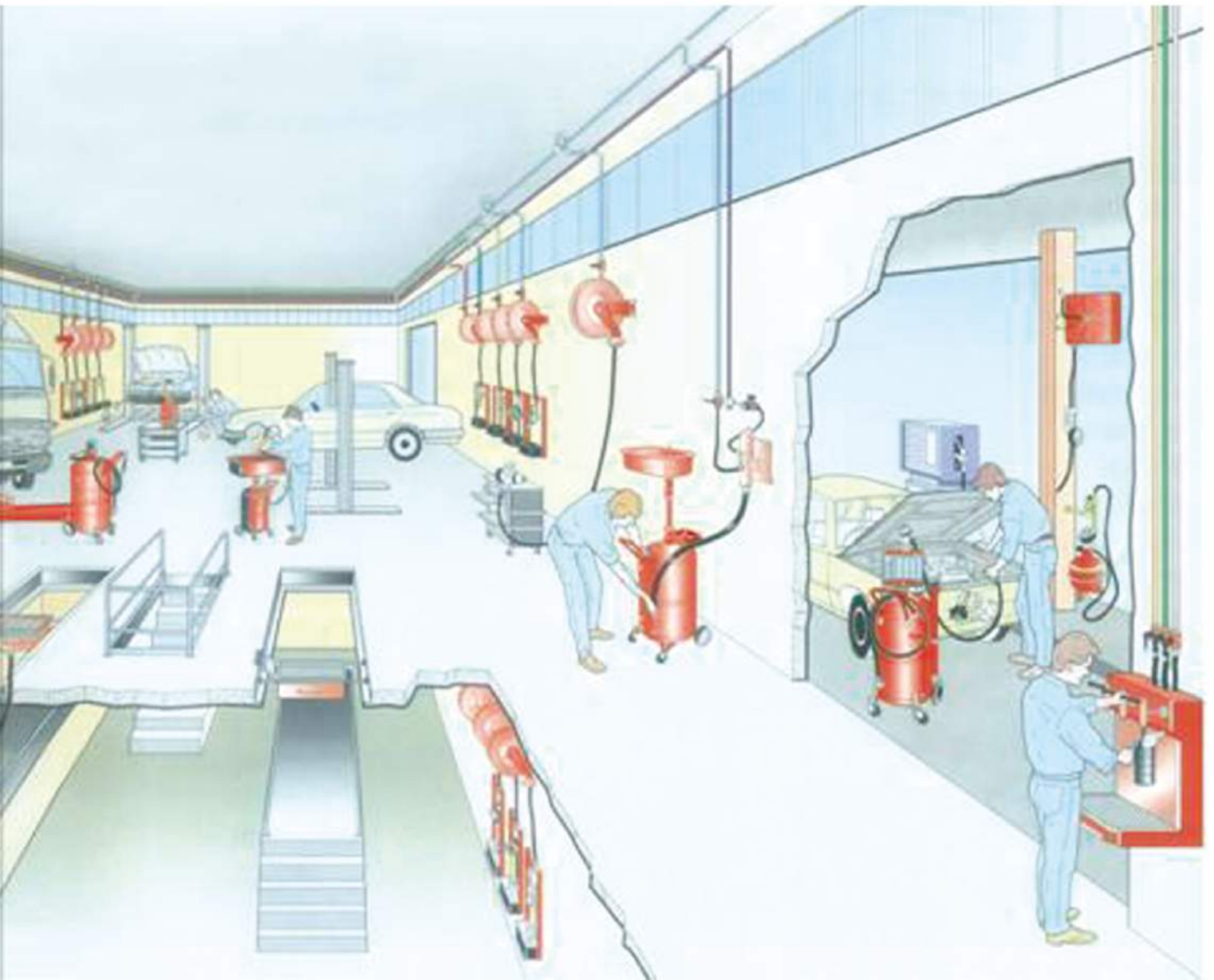



WE ALSO HAVE CEMENT MIXER PRODUCTS...





xieheng
协恒实业
YONGKANG XIEHENG ZHEJIANG PROVINCE INDUSTRY & COMMERCE CO.,LTD.



浙江省永康市协恒实业有限公司

YONGKANG XIEHENG ZHEJIANG PROVINCE INDUSTRY & COMMERCE CO.,LTD.

地址：浙江省永康市经济开发区锡山西路9号 | ADD:NO.9.XiShan West Road,Economic
Development,YongKang,ZheJiang,P.R.C.

电话 /TEL: 0086-579-87236198 87236167 | 传真 /Fax: 0086-579-87237009

邮箱 /E-mail: xieheng@xhtool.com | 邮编 /P.:321300